

WATER FILL JACKET WITH 50MM ROCK WOOL INSULTATION JACKET AND OUT S/S CLADDING

SKETCH DRAWING NOT PRINTED TO ANY SCALE ANY QUESTIONS PLEASE ASK

7.5KW - 10 TO 50 RPM V/SPEED GEAR DRIVE MOTOR

FLANGE MOUNTED BOLT REMOVABLE SECTIONAL LID FOR CLEANING

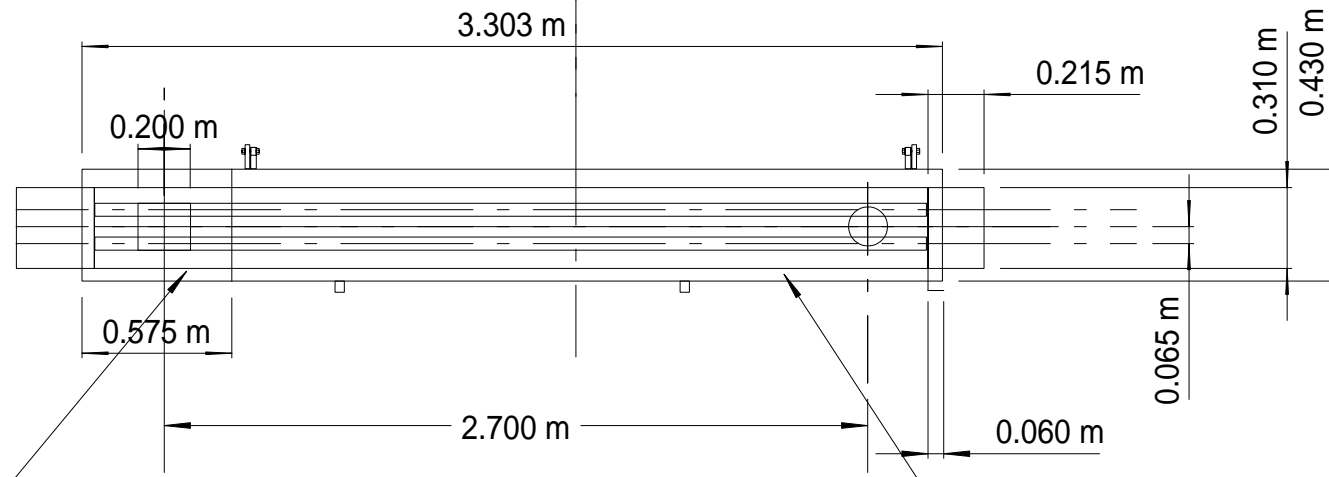
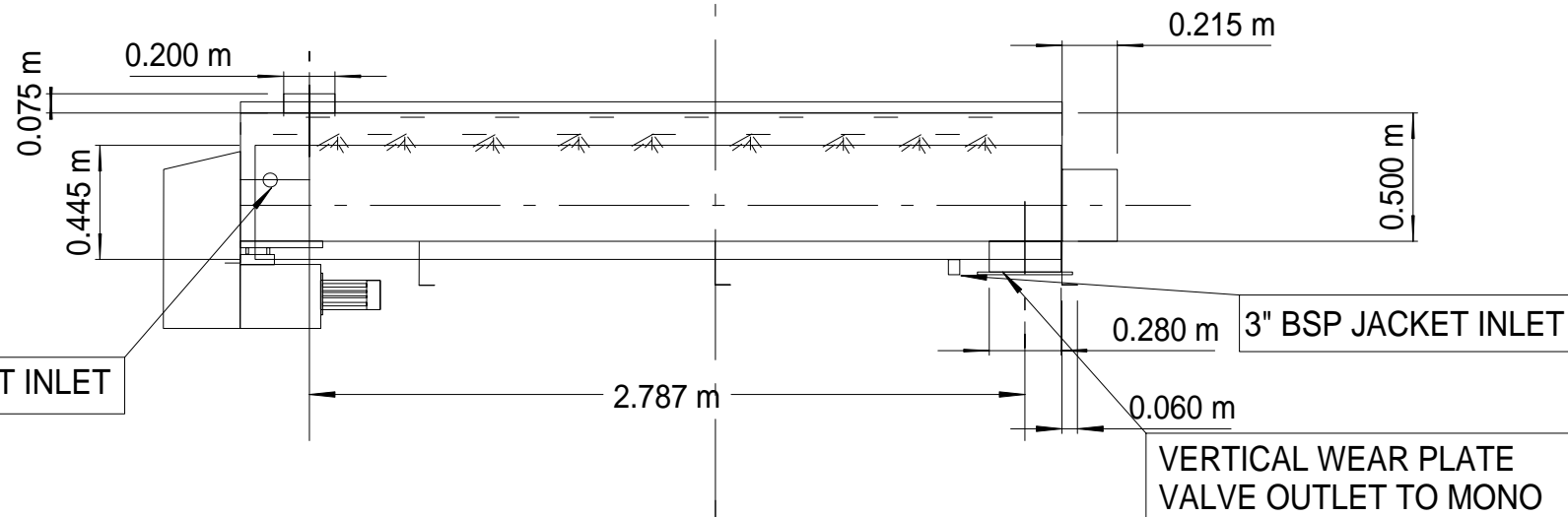

FIXED LID SECTION

HINGED LID SECTION WITH SWING BOLTS FOR CLEANING

ITEM: N4934-10 CONTINUOUS LIME SLAKER S/S JKTD

RIGAL BENNETT GROUP